

Lubes VDU product property prediction and control

By

Y. Zak Friedman, PhD, Petrocontrol

Syazwan Kamarunzaman, PETRONAS

Azura Bt. Azahar, PETRONAS

Seung Yun Nam, Conopt

Lubes VDU product property prediction and control

Overview

Lubes VDU (vacuum distillation unit for production of lube plant feedstock) is different from a fuels VDU. Figure 1 shows a fuels VDU configuration. Reduced crude feed comes from the CDU (atmospheric crude unit) through a furnace and into the flash zone. There are two distillate products: LVGO (light vacuum gasoil) and HVGO (heavy vacuum gasoil). LVGO is diesel range material, going into the diesel pool. HVGO is FCC or hydrocracker feedstock. There is a possibility to also draw vacuum wax, though normally wax is circulated back to the furnace to improve the separation. As is common in vacuum column designs, the draws are from total draw trays. Part of the draw is pumped around through heat exchangers to cool the column, another part is pumped down as hot reflux, and a third part is taken out as product. Economics usually involve maximizing vacuum distillates to meet distillate 90% point targets.

The lubes VDU is a more complex column, having not two but five distillate products. Shown in figures 2 and 3, V1SS, V2SS and V3SS are the main products: lube unit feeds for making 100N, 150N and 500N lube-oils respectively. LVGO, while a valuable diesel material is of lesser value. MVGO is too light to serve as lube unit feed. It is taken into the hydrocracker at a much lower value.

Lube VDU APC economics

What are we to control in APC to maximize unit profitability?

1. The main V1SS, V2SS and V3SS property to be controlled is distillation 50% point, because eventually lube-oil viscosity is a function of feedstock 50% point. While KW (Watson K factor), a measure of aromatics, also affects viscosity, the lube unit reactors saturate aromatics, modifying KW, and thus the starting feed KW is inconsequential.
2. The second lube feed property of importance is distillation 95% point. The difference between 95% and 50% defines the distillation range and hence yield of the three lube feeds.
3. Our initial APC strategy maximized total yield ($V1 + V2 + V3$), only to find out that relative yields are also of importance because in the end the lube plant must satisfy local demand. Those relative yields then became a third property or importance.
4. Column separation is also of importance, and we can manipulate the internal reflux profile to reduce heavy tail contamination
5. Unfortunately there are no side strippers and hence light tail contamination is unavoidable. Light tail eventually affects the finished lube-oil yield, but there is not much we can do about it in APC.
6. LVGO is to be maximized to diesel specification. Thus, MVGO is minimized between diesel target cutpoint and V1SS target 50% point and cutpoint range range.

VDU inferential variables

1. LVGO 90% point
2. MVGO 90% point in open loop
3. V1SS, V2SS, V3SS 50% points
4. V1SS, V2SS, V3SS 95% points
5. V1SS, V2SS, V3SS 5% points in open loop
Given that there are no side strippers and that we are already controlling lube feed boiling ranges, nothing else can be done to control 5% points
6. V1SS, V2SS, V3SS viscosities @ 100°C in open loop
As stated above, the specification is not lube feed viscosity but final lube product viscosity, and we attempt to predict that final viscosity
7. Top dew point inference
For corrosion protection. The overhead flow is mostly steam
8. MVGO internal reflux (that is a partial draw tray with no Pumpdown arrangement)

Main manipulated variables

- Pumparounds and pumpdowns
Manipulated for product cutpoint and internal reflux profile control
 - MVGO draw
 - Coil outlet temperature
 - Manipulate for control of V3SS 95% point
 - Bottom steam Manipulated at target ratio
- ### **Comparison of inferential models against lab**
- We use two months trends to illustrate the inferential fidelity. Inferential predictions are blue lines, whereas lab data is shown as continuous green lines. These green lab data have a meaning only at the time when a change of value takes place. That is the time when a new test data point had been written in. The figures of interest are:
 - Figure 4. LVGO and MVGO 90% point predictions and lab values
 - Figure 5. V1SS, V2SS and V3SS 50% point predictions and lab values
 - Figure 6. V1SS, V2SS and V3SS 95% point predictions and lab values
 - Figure 7. V1SS, V2SS and V3SS viscosity predictions and lab values

We can see that the distillation predictions are quite good. The viscosity predictions are not perfect but they do not need to be, as the intention is to predict viscosities of the final lube product and not of the lube feedstock.

Operation under APC

We use two months trends to illustrate the inferential fidelity. Inferential predictions are blue lines, whereas lab data is shown as continuous green lines. These green lab data have a meaning only at the time when a change of value takes place. That is the time when a new test data point had been written in. The figures of interest are:

- Figure 4. LVGO and MVGO 90% point predictions and lab values
- Figure 5. V1SS, V2SS and V3SS 50% point predictions and lab values
- Figure 6. V1SS, V2SS and V3SS 95% point predictions and lab values
- Figure 7. V1SS, V2SS and V3SS viscosity predictions and lab values

We can see that the distillation predictions are quite good. The viscosity predictions are not perfect but they do not need to be, as the intention is to predict viscosities of the final lube product and not of the lube feedstock.

APC benefits come in three flavors. First, controlling the 50% points and product cutpoint ranges guarantees stable quality products at the correct yields. That maximizes not only utilization of the lube plant but also lube yields. Second, APC maximizes the yield of diesel at the expense of MVGO. Figures 8 and 9 show key product yields before and after APC. As can be seen, LVGO yield went from 14 to 16%, whereas MVGO, came down from 12 to 10%. The price difference between those two products: diesel versus hydrocracker feed is large, yielding high benefits. Third before APC the column was operating at high wash zone loading and unnecessarily high COT (coil outlet temperature). Figure 10 trends the change in column energy use after commissioning. It can be seen that over a short time COT dropped 5°C, wash zone flow dropped 10 M³/Hr. An added bonus was a drop in flash zone pressure of 5 mmHg. Figure 11 trends this sort of energy improvement KPIs over 300 days, showing the gradual improvement under APC.

Conclusions

Quality inferences plus understanding of the economics have permitted visible operational improvements of this column. The yield of LVGO is maximized against MVGO and lube feed cutpoints are consistently at targets. The furnace fuel demand dropped about 3%. APC service factor is high.

Figure 1. Fuels vacuum column configuration

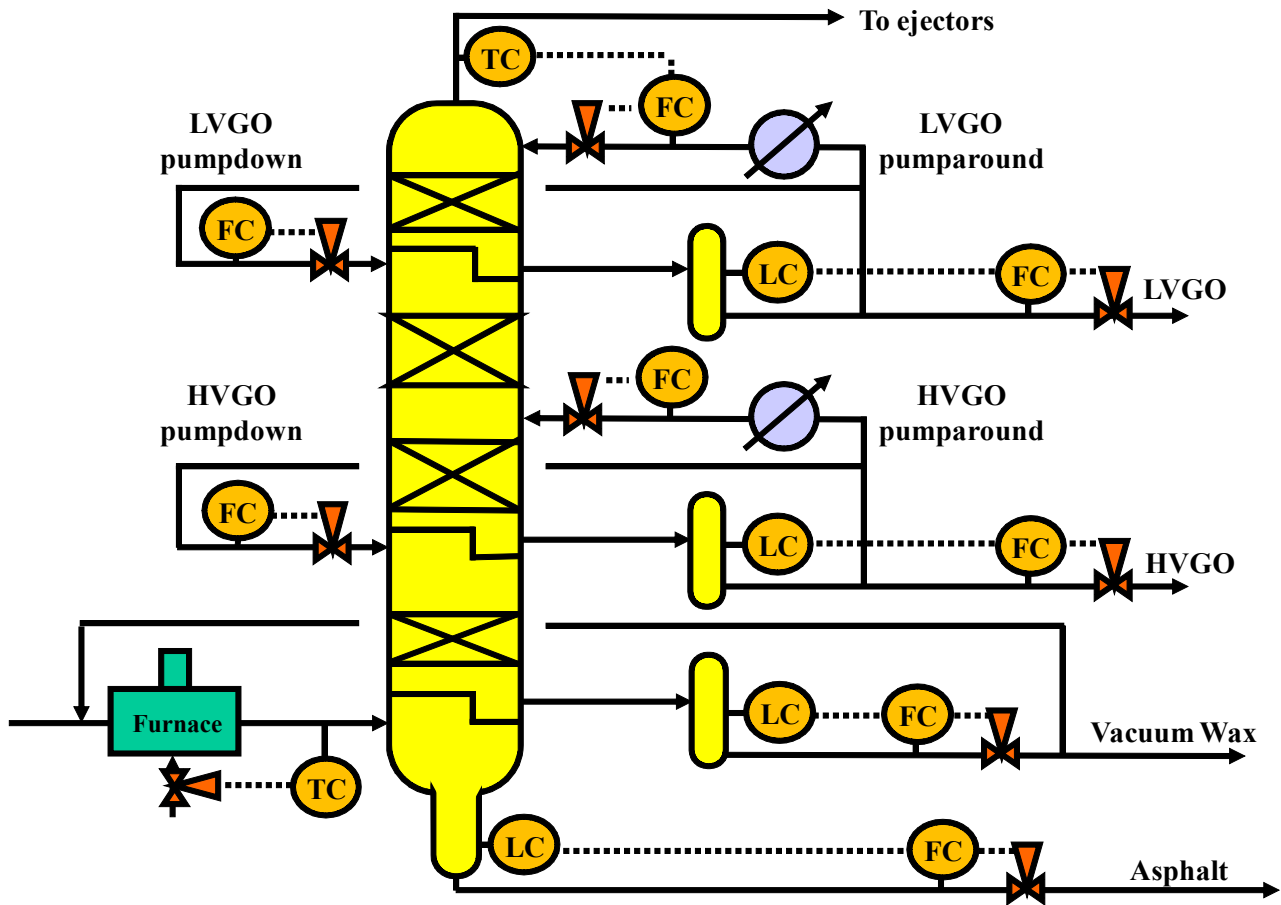

Figure 2. Lubes vacuum fractionator upper part

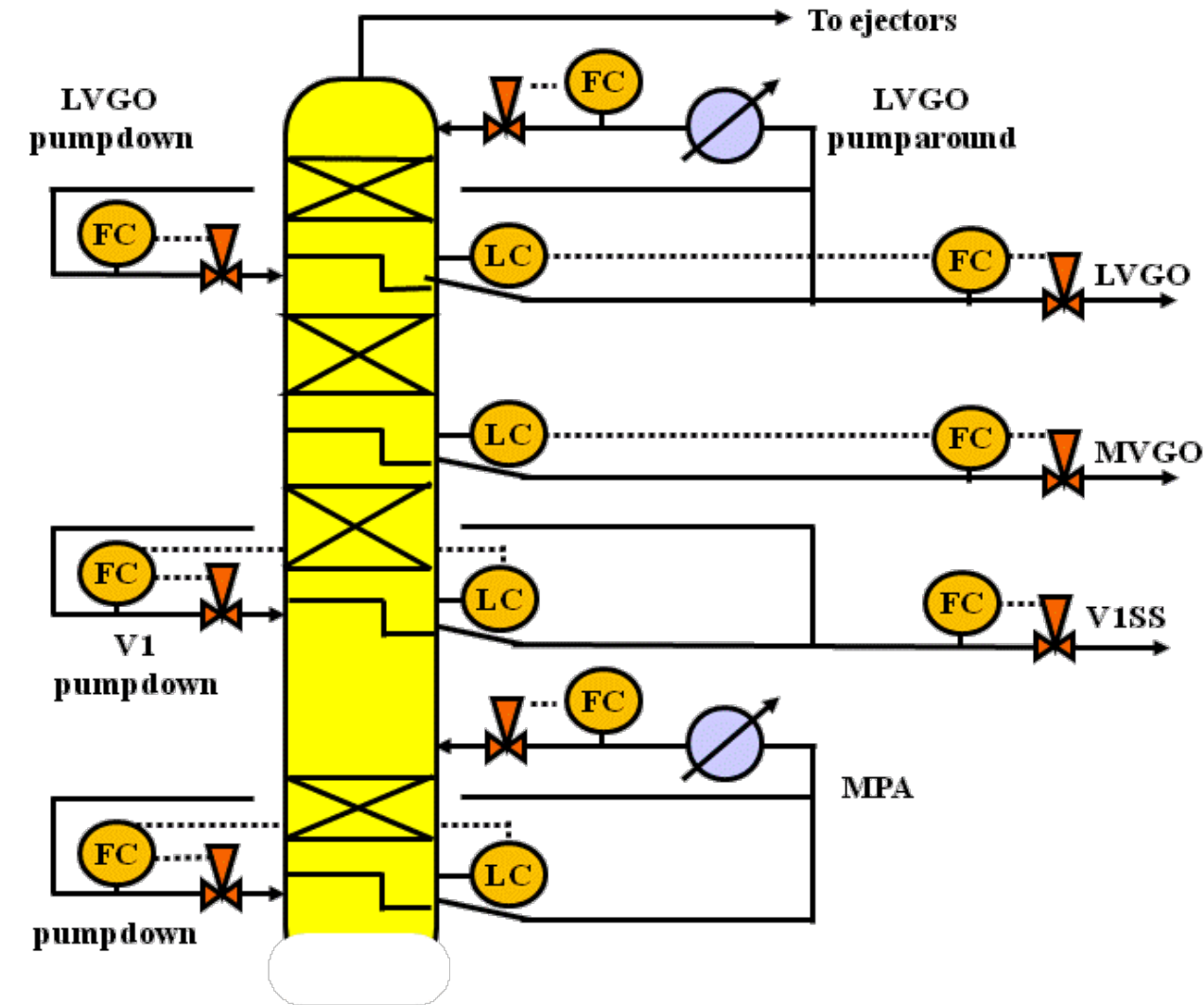

Figure 3. Lubes vacuum fractionator lower part

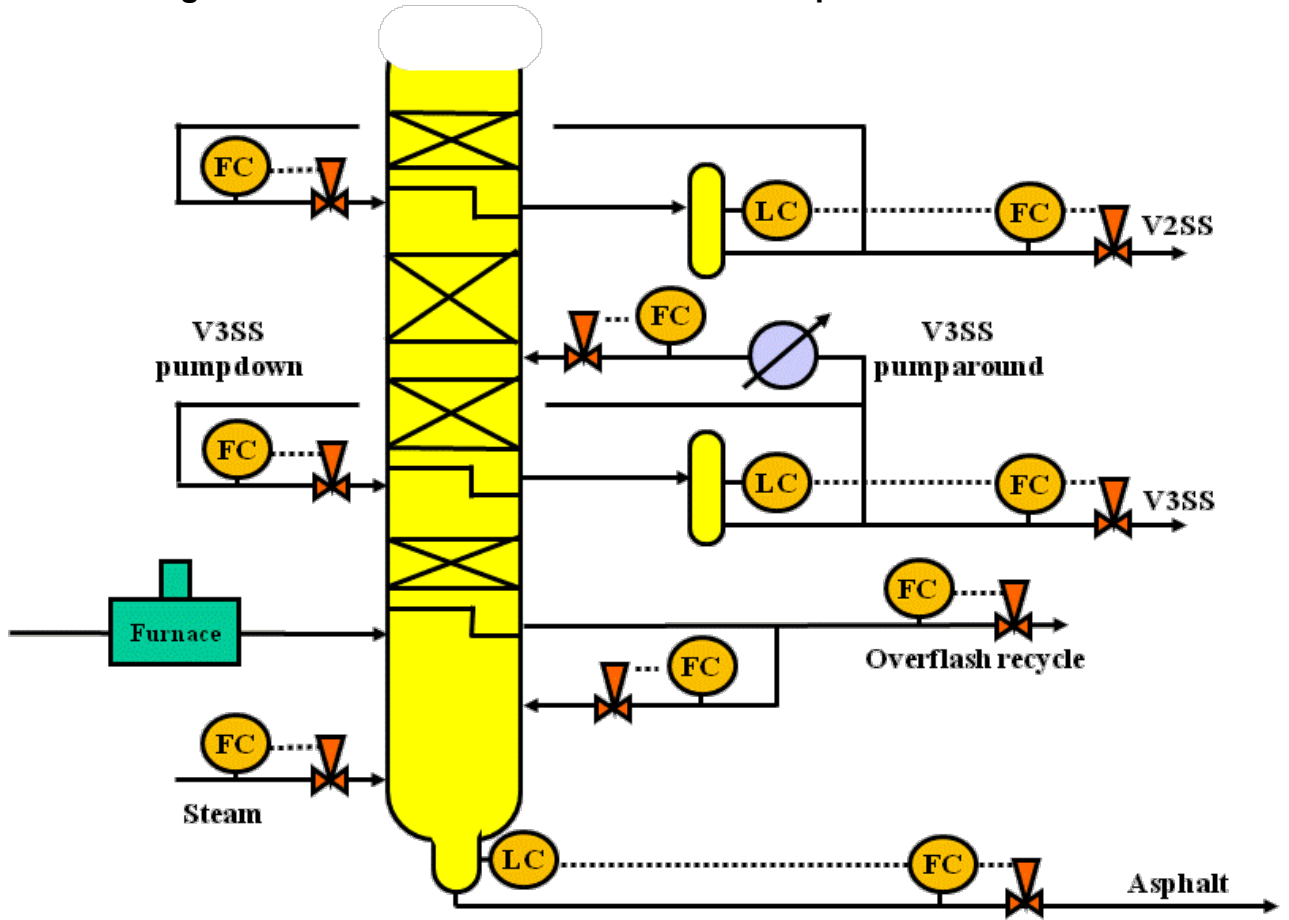

Figure 4. LVGO, MVGO 90% point trend against lab

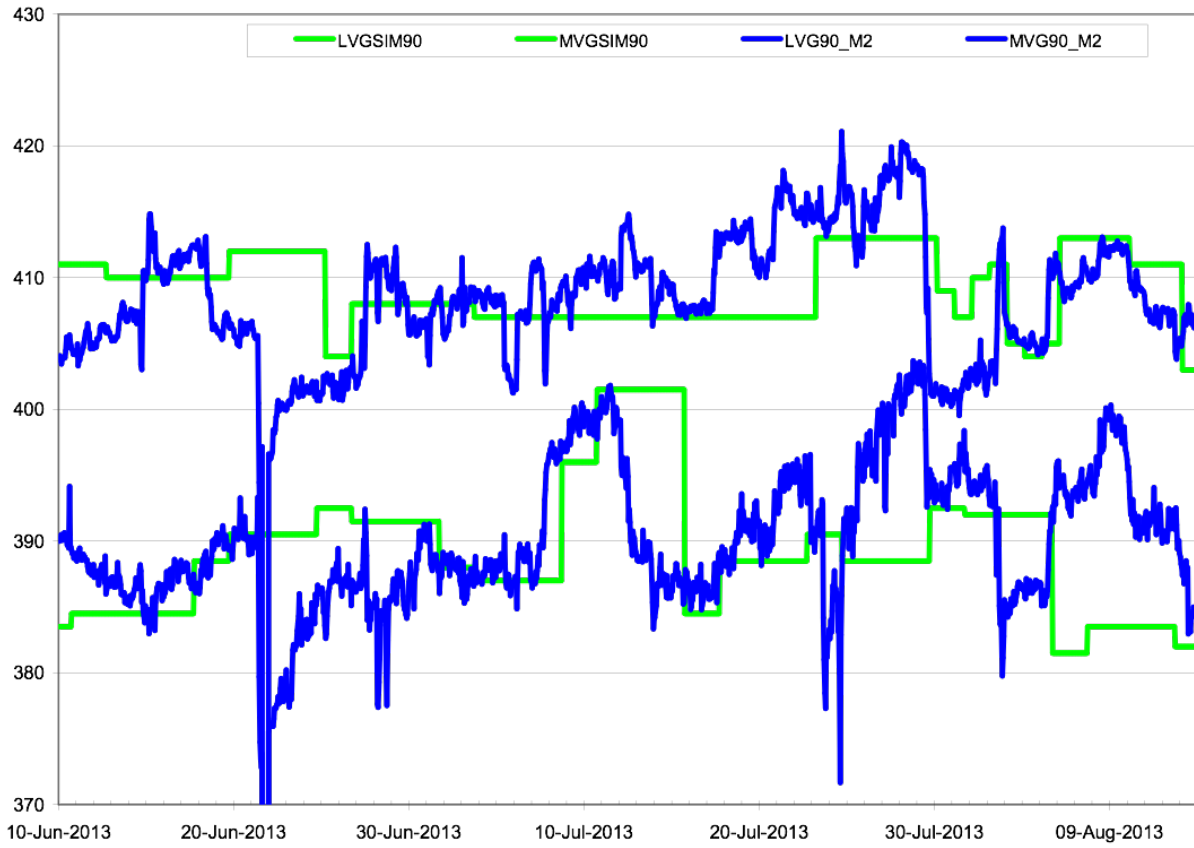

Figure 5. V1SS, V2SS, V3SS 50% point trend against lab

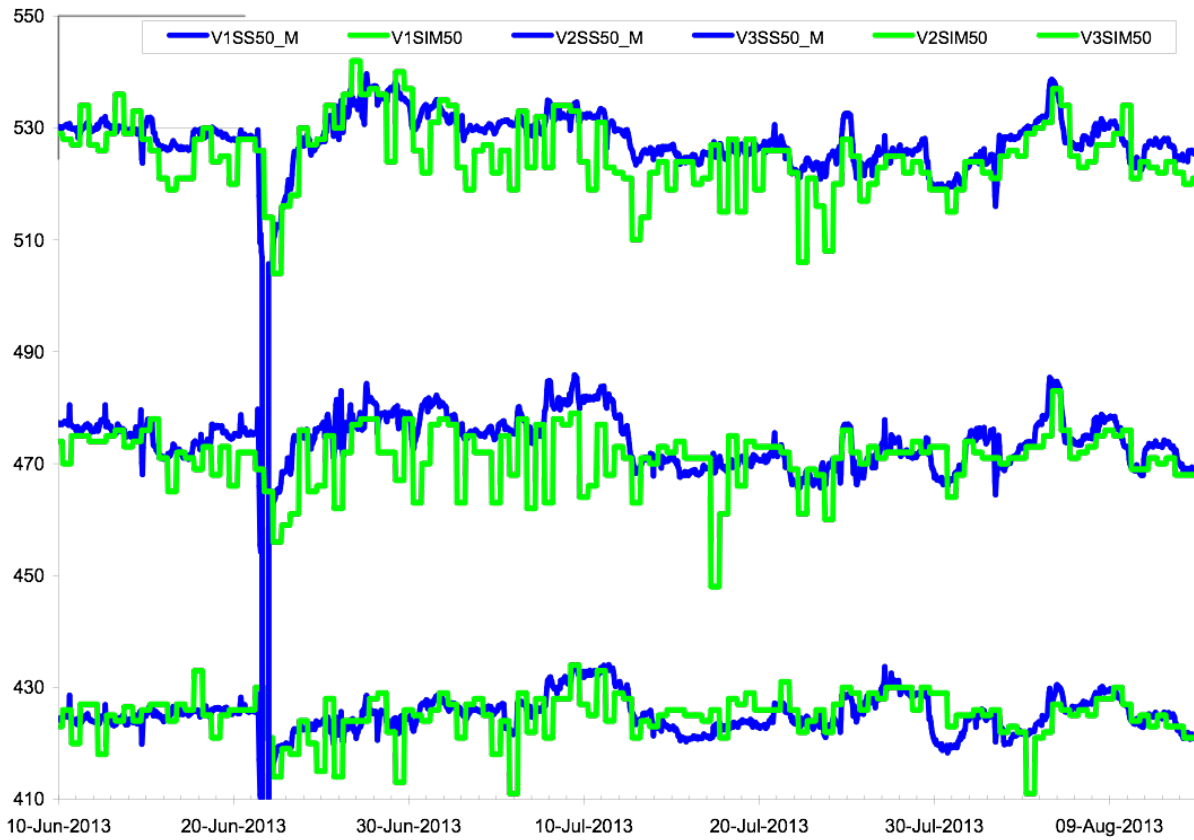

Figure 6. V1SS, V2SS, V3SS 95% point trend against lab

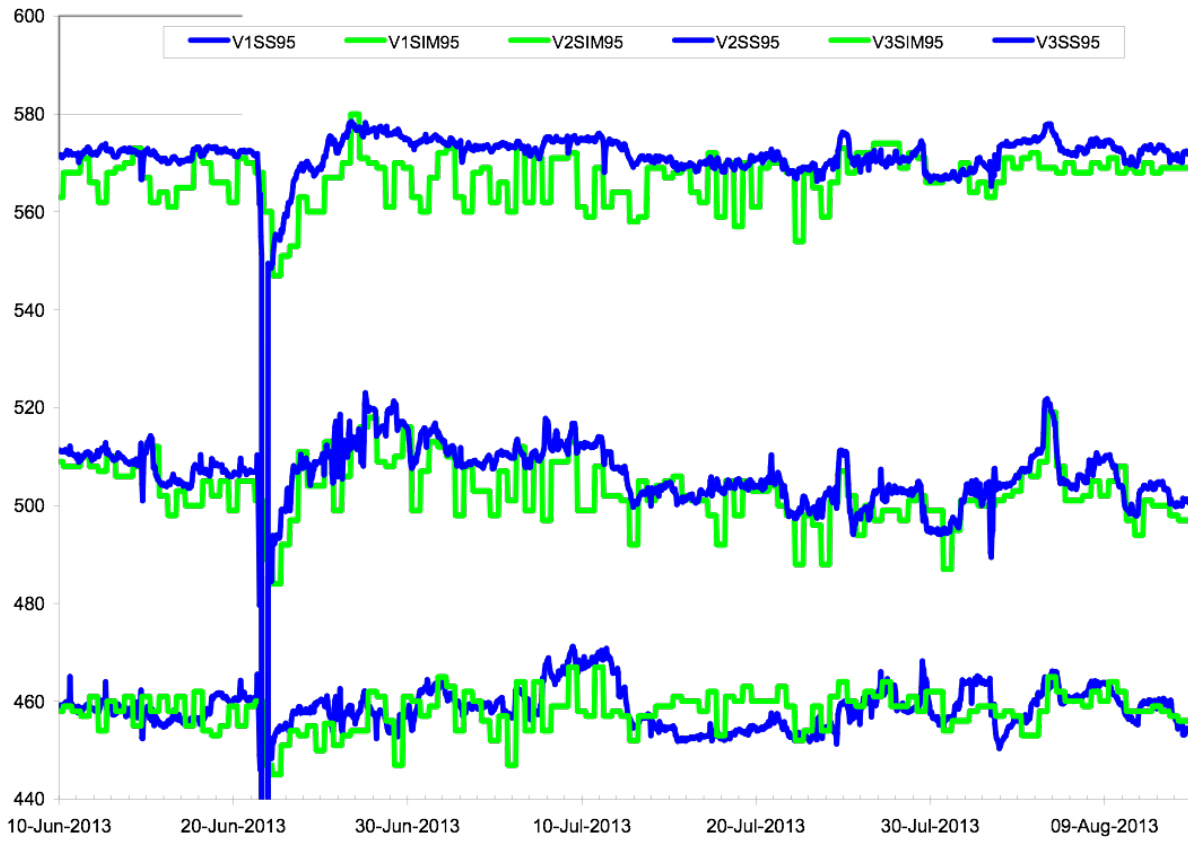

Figure 7. V1SS, V2SS, V3SS viscosity @ 100°C trend against lab

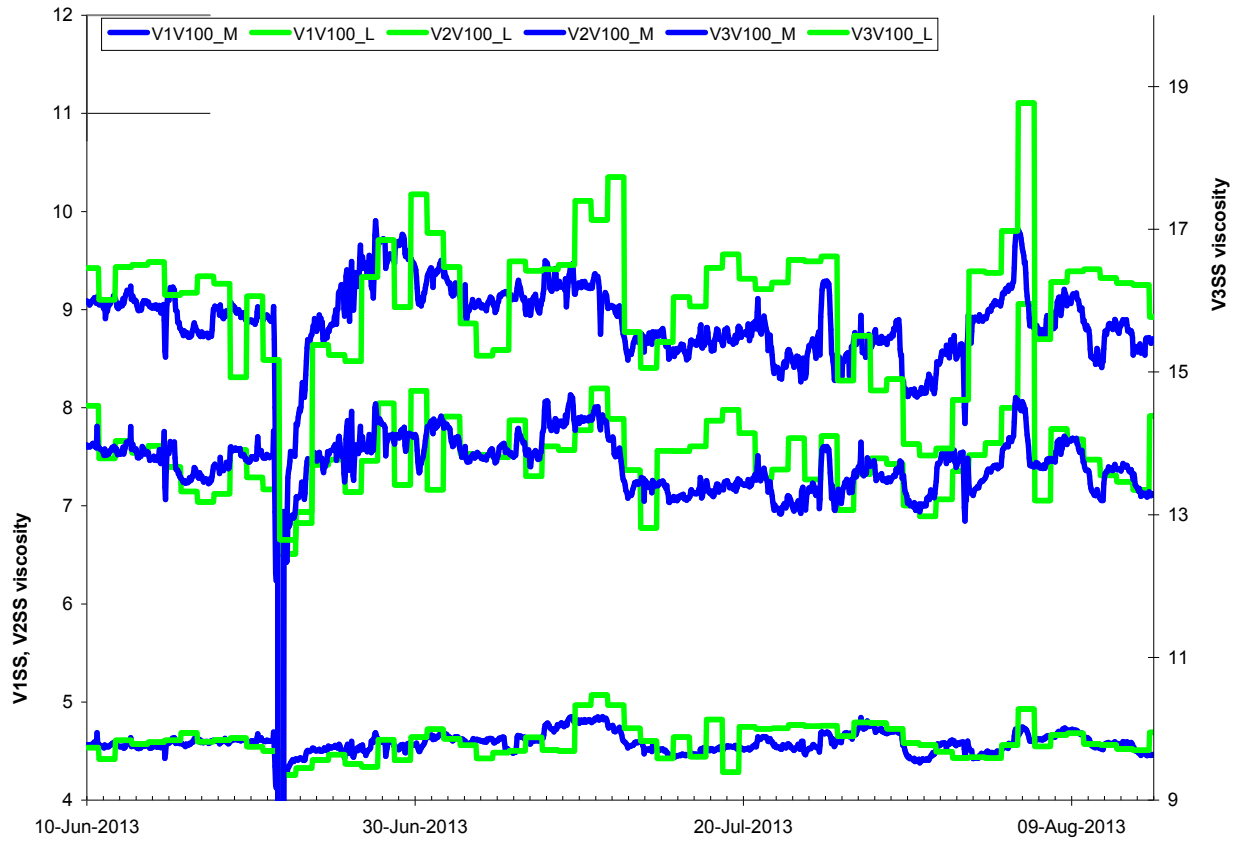

Figure 8. Key product yields before APC

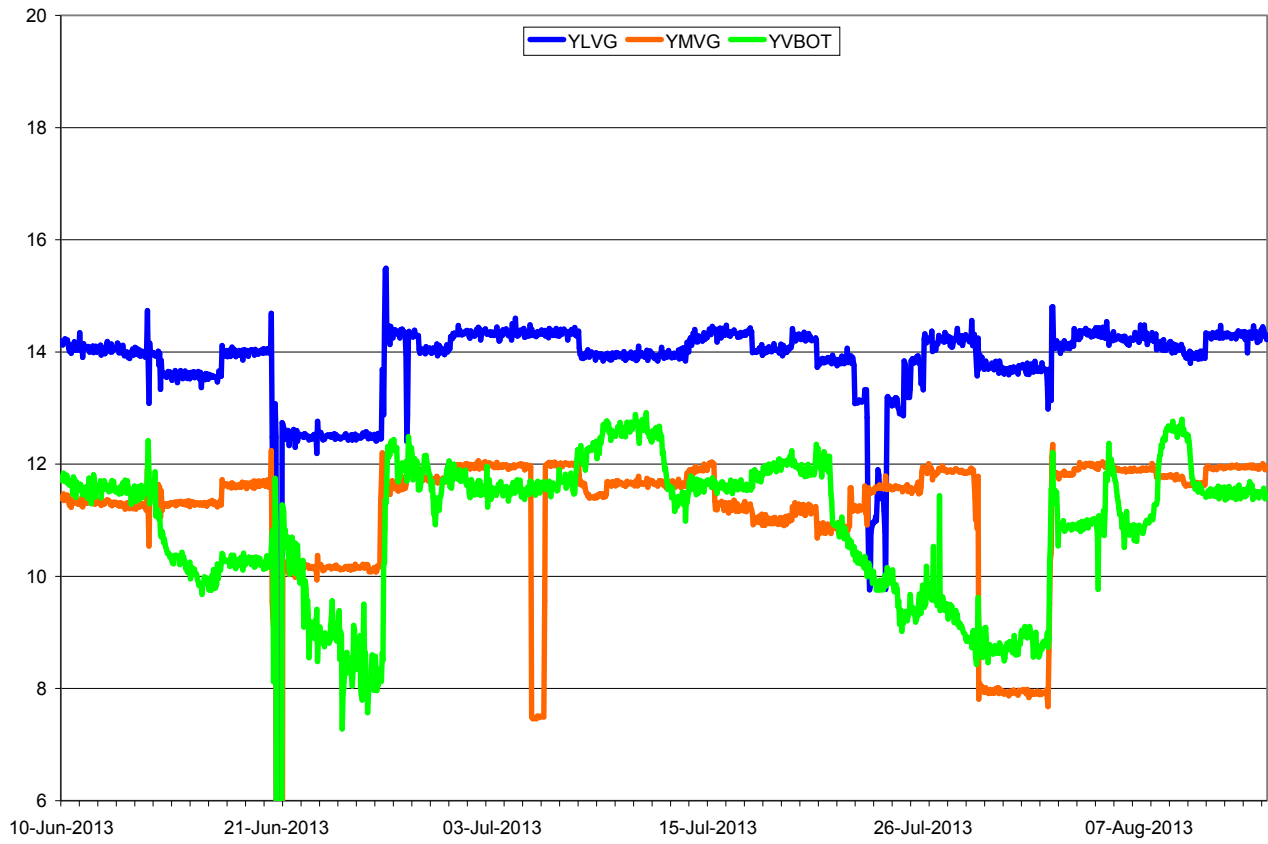

Figure 9. Key product yields with APC

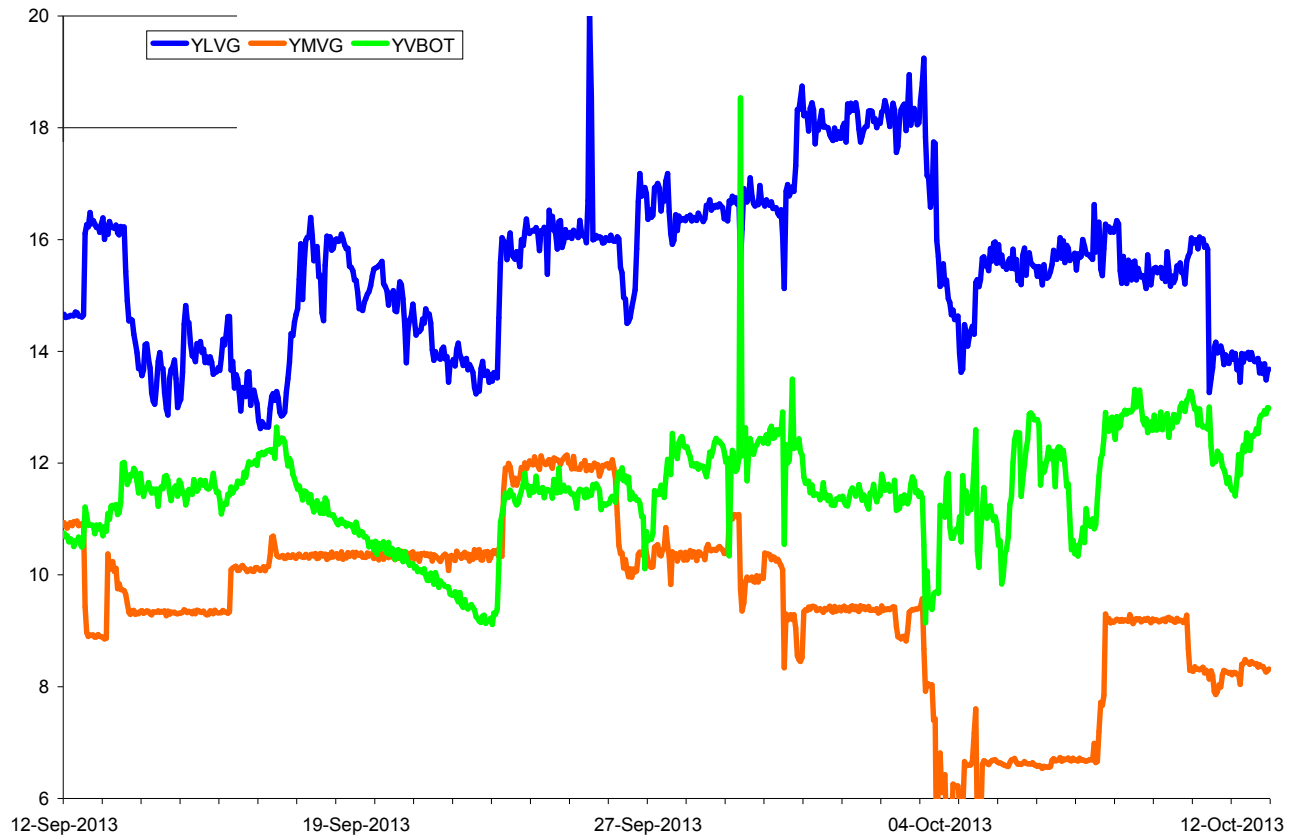

Figure 10. Energy optimization

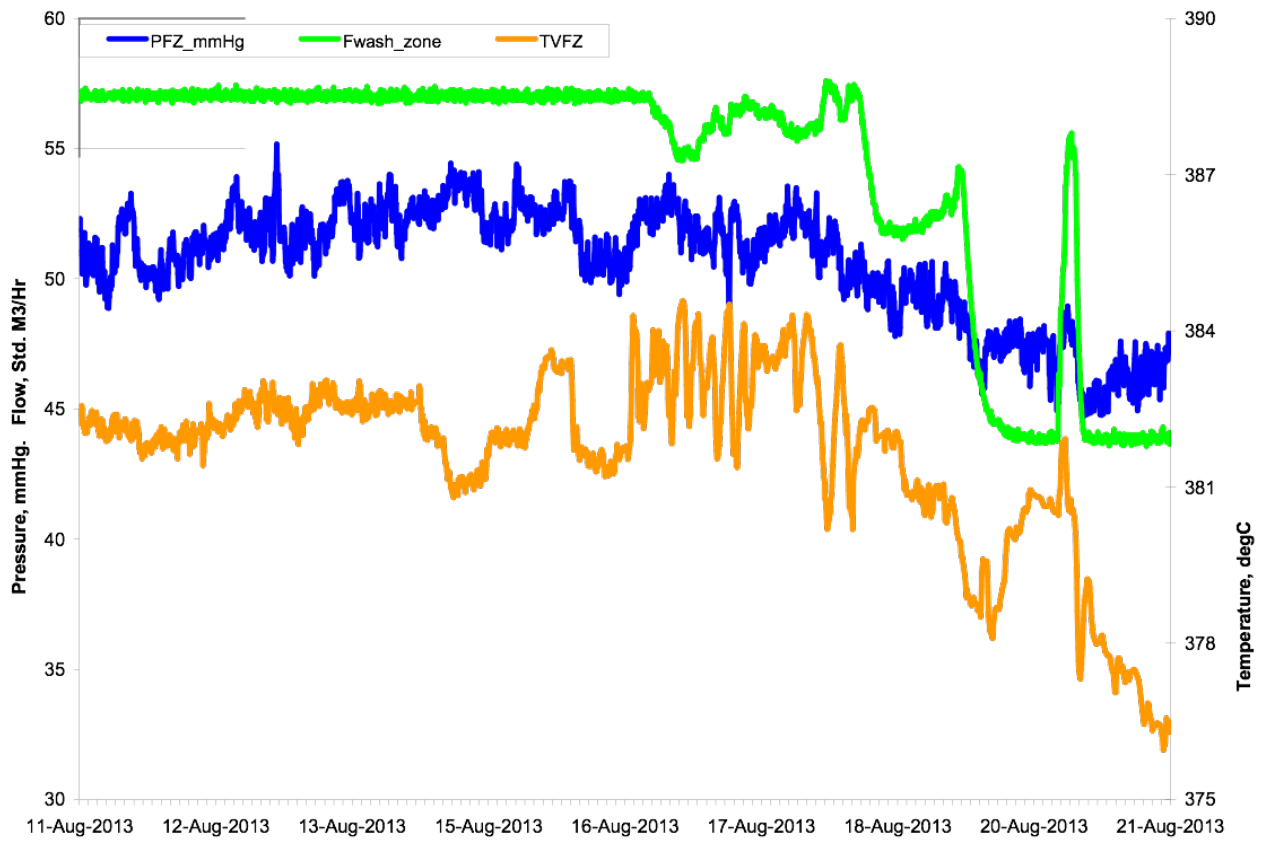

Figure 11. Energy improvement over 300 days

